



Genuine Parts

**PRECAUTIONS:**

- ❑ Read ALL instructions before installing instrument.
- ❑ Follow ALL safety precautions when working on vehicle-wear safety glasses!
- ❑ ALWAYS disconnect (-) negative battery cable before making electrical connections.

**HELP?:**

- ❑ If after reading these instructions you don't fully understand how to install your instrument(s), contact your local Stewart Warner distributor, or contact our Technical Support Team toll free at **1-800-676-1837**
- ❑ Additional applications information may be found at [www.stewartwarner.com](http://www.stewartwarner.com).

**GENERAL APPLICATION:**

- ❑ 12-volt DC negative (-) ground electrical systems (11-20 VDC operating voltage range for the speedometer, 11-16 VDC for the Light bulb).
- ❑ Input: 3,000 to 100,000 Pulses Per Mile, Hall effect sensor or magnetic sender.

**Installation Instructions**  
*Speedometer 3-3/8"*

1

**SPEEDOMETER MOUNTING (Figure 1):**

- ❑ Recommended panel cut-out (hole size) for 3-3/8" speedometer is 3-3/8".
- ❑ Secure the speedometer in the hole using the supplied bracket and nuts. Be sure to wire the speedometer before mounting.

Figure 1

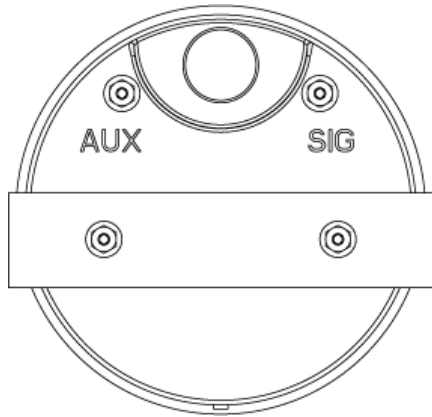

3

2

**SPEEDOMETER WIRING (Figure 2, 3 & 4):**

1. Disconnect negative (-) battery cable.
2. Using 18-ga. wire, connect the **(NEG)** terminal to a clean (rust/paint-free) ground, preferably battery negative terminal.
3. Using 18-ga. wire, connect the **(POS)** terminal to a switched +12V source, like the ignition wire.
4. Using 18-ga. wire, connect the **(SIG)** terminal or **(AUX)** terminal to the speedometer sender or magnetic sensor (refer to figure 3 and 4 for sender wiring). Factory speedometer senders may be used as well. Refer to the vehicle service manual or your dealer for factory speedometer sender wiring information.
5. The **CALIBRATION** button can be mounted in a convenient location that is easily within reach of the driver or it can be removed after calibration. If removed be sure to keep the button in a safe place for calibrating in the future.
6. Remove the rubber cover from the window on the back of the speedometer. Connect the **CALIBRATION** wire to the header pins located to the right side of the window.
7. There are two (2) wires for the lighting. Connect the **(WHITE)** lighting wire to the dash lighting circuit or to a +12V switched circuit. Connect the **(BLACK)** lighting wire to a chassis ground.
8. Reconnect the negative (-) battery cable.
9. Calibrate the speedometer. Refer to the calibration set-up section. Test instrument to ensure that it is working properly.

4

Figure 2

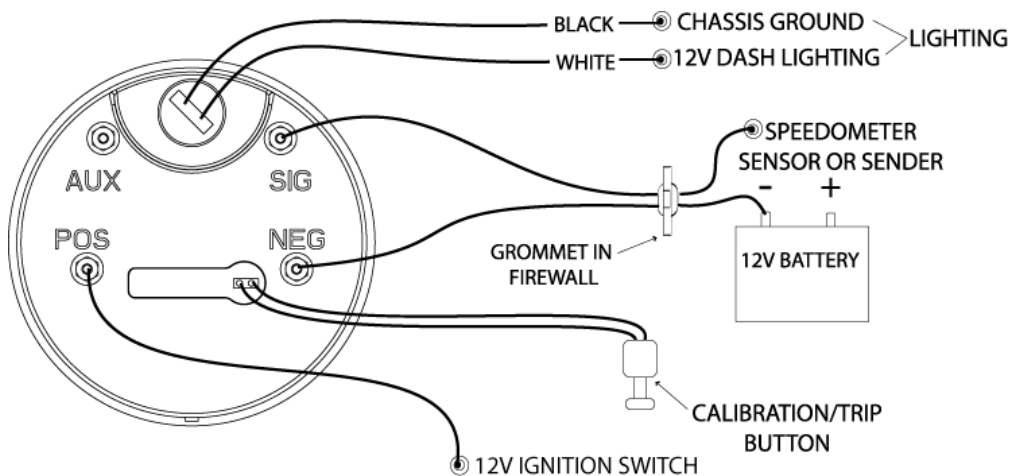

5

6

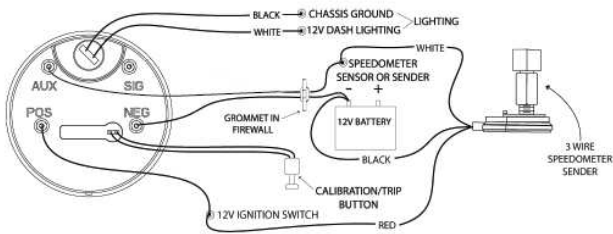

Figure 3

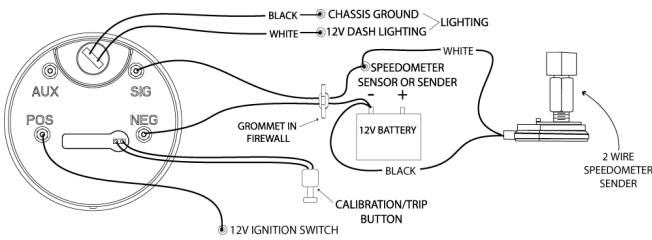

Figure 4

**CALIBRATION (Pulses Per Mile):**

Pulses Per Mile (PPM) is the number of pulses that the speedometer receives for one (1) mile driven. The speedometer needs to know this information to accurately indicate speed. Stewart Warner speedometers accept a very wide range of PPM (3,000 to 100,000 PPM). This is very convenient when making changes to differential gear ratios and tire sizes. Just recalibrate the speedometer whenever changes are made and the speedometer will accurately indicate speed.

**SIGNAL INTERFACING:**

Stewart Warner speedometers are designed to work with both hall effect senders and magnetic pickup sensors. The input level can range from TTL 5V square wave (hall effect) to AC sign wave signals (magnetic pickup).

If using a 3 wire sensor connect the output of the sensor to the (AUX) terminal as shown in Figure 3.

If using a 2 wire sensor connect the output of the sensor to the (SIG) terminal as shown in Figure 4.

7

8

**CALIBRATION SET-UP (Figure 5 & 6):**

1. With the ignition off, press and hold the **CALIBRATION** button.
2. Turn the ignition on then release the **CALIBRATION** button.
3. The dial will indicate half scale to verify that calibration mode has been accessed (Figure 5).
4. Once in calibration mode momentarily press the **CALIBRATION** button a second time to begin calibration. The dial will sweep between 0 and half scale to indicate that it is currently counting pulses (Figure 6).
5. Drive the vehicle EXACTLY one (1) measured mile then stop.
6. At the end of the measured mile momentarily press the **CALIBRATION** button a third time to complete the calibration.
7. If the number of PPM is between 3,000 and 100,000 the speedometer will accept the calibration and enter normal operation.

Figure 5

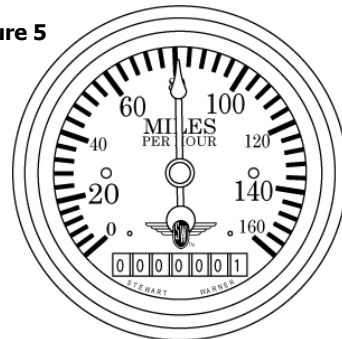
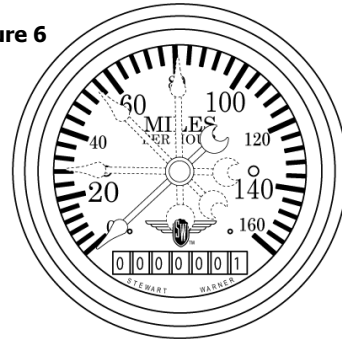

Figure 6



9

10

**TROUBLESHOOTING:**

**Q:** My speedometer does not respond at all, what do I do?

**A:** Check all of the wiring connections and power to the speedometer.

1. If the speedometer needle *goes* to zero when powered up, but does not respond when the vehicle is at speed, there is no signal to the (SIG) terminal. Check to ensure that the terminal is wired to the proper location for a valid signal.
2. If the speedometer needle does not go to zero when powered up, the speedometer is not grounded properly or does not have power to the (POS) terminal. Check to ensure a good chassis ground. Verify that the (POS) terminal has a 12VDC supply.

**Q:** My speedometer does not read correctly, what do I do?

**A:** Recalibrate the speedometer.

1. Be sure that you are driving exactly one (1) mile. The speedometer calibration accuracy is dependent upon driving exactly one (1) mile.
2. Spinning the tires will skew calibration and the speedometer will not be accurate.

**Q:** My speedometer pointer is jumpy or erratic?

**A:** Use a 3 wire hall effect type sensor and connect as shown in Figure 3.

1. Excessive electrical noise can interfere with the low amplitude signal that is generated by a magnetic pickup type sensor at low speeds.

**CLEANING DIRECTIONS:**

For proper cleaning of instrumentation/accessories, use a glass cleaner or mild detergent with a spray on and wipe method.

**WARRANTY INFORMATION:**

**TWO (2) YEAR LIMITED WARRANTY.** Stewart Warner products are warranted against defects in workmanship and materials for a period of two (2) years from the date of purchase. Proof-of-purchase is required; otherwise, the warranty period shall default to two (2) years from date-of-manufacture (as indicated by the date code on the product). See detailed Warranty Policy for other Terms & Conditions.

STEWART WARNER

1-800-676-1837

www.stewartwarner.com

11

12